



# PRIMO<sup>®</sup> XXL

Comfort Seat with  
Pneumatic Suspension



**GRAMMER**

# TECHNICAL DATAN

## PRIMO® XXL

Despite this seat's low height, its large suspension travel and low-frequency technology actively protect the user. It's also very easy to set the pneumatic suspension and extra-high backrest with mechanical lumbar support. The push-button weight adjustment feature is especially advantageous in vehicles used by changing drivers.



Pneumatic suspension



Low-Frequency Suspension



Mechanical Lumbar Support



Manual Weight Adjustment

### Features ● Standard ○ Optional

	PRIMO® XXL
Article no. fabric Compressor 12V	1293476
Shock absorber nonadjustable	●
Suspension	
Pneumatic suspension with compressor	●
Low-frequency suspension	●
Suspension stroke 110 mm	●
① Weight adjustment 45 - 170 kg, pneumatic	●
② Fore/aft adjustment 210 mm	●
③ Lumbar support mechanical	●

	PRIMO® XXL
④ Adjustable backrest angle	●
⑤ Restraint system	●
Seat cushion width	450 mm
Operator presence switch (OPS)	●
<b>OPTIONAL FEATURES</b>	
⑥ Document box	○
⑦ Armrests height-adjustable	○
Fore/After isolator*	○
⑧ Seat heating	○

\* Force/after isolator not for earth-moving machinery

### Measurements (installation dimensions)

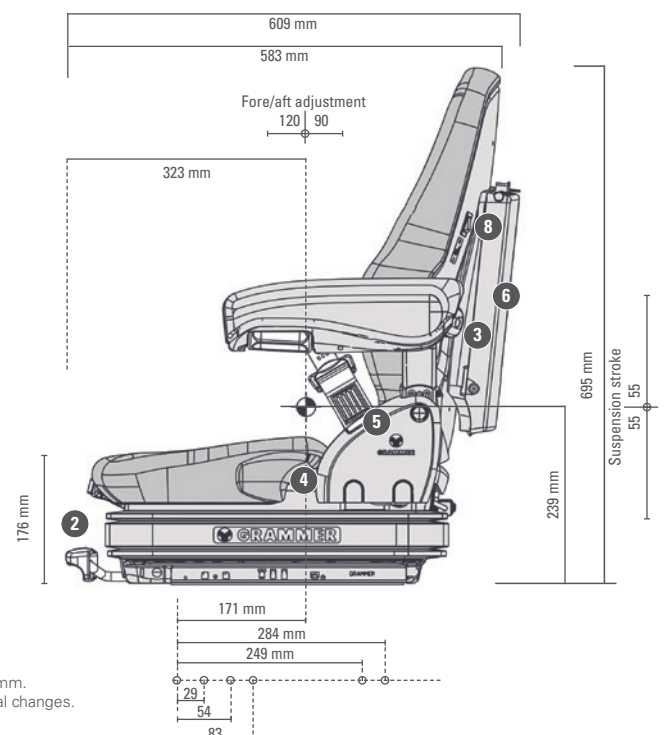
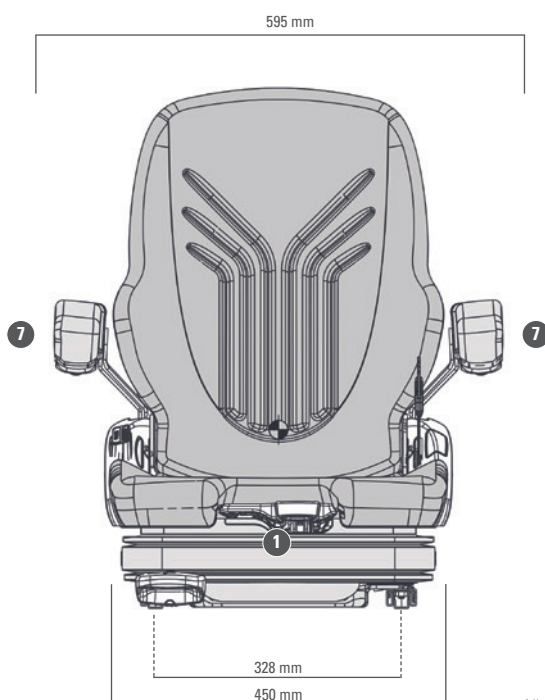

All dimensions in mm.  
Subject to technical changes.