



PRIMO[®] XL

Comfort Seat with Low-Frequency
Pneumatic Suspension



GRAMMER

TECHNICAL DATA

PRIMO® XL

Operable on a 12 V or 24 V power source, this seat's low-frequency suspension ensures good comfort. It can be easily set to the driver's weight (between 45 and 170 kg) simply by pressing a button. The upper seat section, retention system, and lumbar support can also be set to optimally meet the user's needs.



Pneumatic suspension



Low-Frequency Suspension



Mechanical Lumbar Support



Manual Weight Adjustment

Features ● Standard ○ Optional

| | PRIMO® XL |
|--|-----------|
| Article no. imitation leather | |
| Compressor 12V | 1293489 |
| Compressor 24V | 1293478 |
| Shock absorber nonadjustable | ● |
| Suspension | |
| Pneumatic suspension with compressor | ● |
| Low-frequency suspension | ● |
| Suspension stroke 110 mm | ● |
| ① Weight adjustment 45 - 170 kg, pneumatic | ● |
| ② Fore/aft adjustment 210 mm | ● |
| ③ Lumbar support mechanical | ● |

| | PRIMO® XL |
|--------------------------------|-----------|
| ④ Adjustable backrest angle | ● |
| ⑤ Backrest extension | ● |
| ⑥ Restraint system | ● |
| Seat cushion width | 470 mm |
| Operator presence switch (OPS) | ● |
| OPTIONAL FEATURES | |
| ⑦ Document box | ○ |
| ⑧ Armrests height-adjustable | ○ |
| Fore/After isolator* | ○ |
| ⑨ Seat heating | ○ |

* Force/after isolator not for earth-moving machinery

Measurements (installation dimensions)

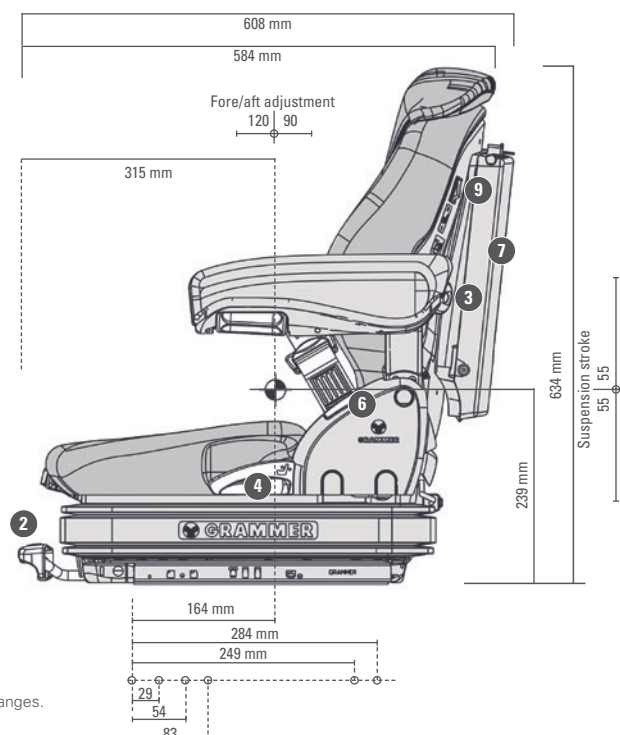
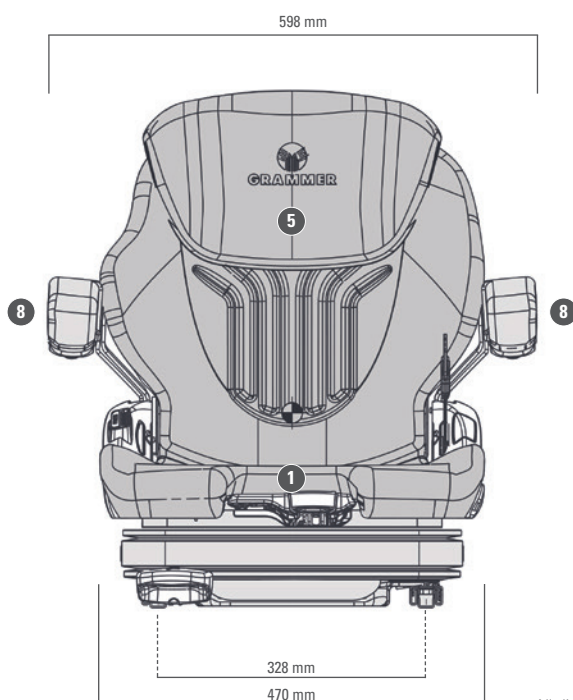

All dimensions in mm.
Subject to technical changes.