



# PRIMO® EL PLUS

Premium Seat with  
Active Weight Adjustment



**GRAMMER**

# TECHNICAL DATA

## PRIMO® EL PLUS

The low-frequency suspension with travel of 110 mm in the Primo EL Plus delivers outstanding comfort despite the seat's low height. Its premium package of comfort-enhancing features includes active pneumatic weight adjustment, which is very advantageous with frequently changing drivers. The seat automatically sets itself to the operator's weight to maximize vibration attenuation. Integrated heating and a mechanical lumbar support are included as standard features.



Pneumatic suspension



Low-Frequency Suspension



Mechanical Lumbar Support



Electronic Weight Adjustment



Passive Climate System

**Features** ● Standard ○ Optional

	PRIMO® EL PLUS
Article no. fabric Compressor 12V	1292328
Shock absorber nonadjustable	●
Suspension	
Pneumatic suspension with compressor	●
Low-frequency suspension	●
Suspension stroke 110 mm	●
Weight adjustment 45 - 170 kg, electronic	●
Climate system passive	●
① Fore/aft adjustment 210 mm	●
② Lumbar support mechanical	●
③ Adjustable backrest angle	●

	PRIMO® EL PLUS
④ Restraint system	●
Seat cushion width	530 mm
⑤ Seat heating	●
⑥ Adjustable seat cushion depth and angle	●
Operator presence switch (OPS)	●
<b>OPTIONAL FEATURES</b>	
⑦ Document box	○
⑧ Armrests foldable	○
Fore/aft isolator*	○
⑨ Backrest extension	○

\* Force/after isolator not for earth-moving machinery

### Measurements (installation dimensions)

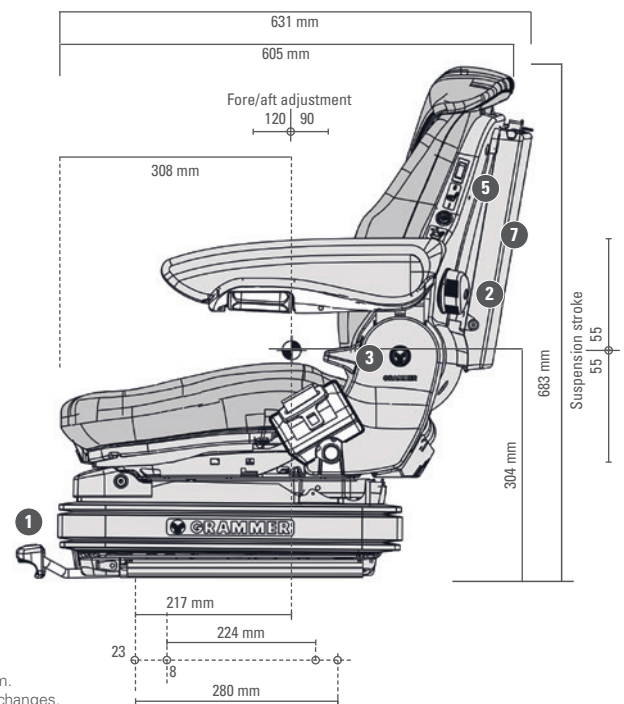
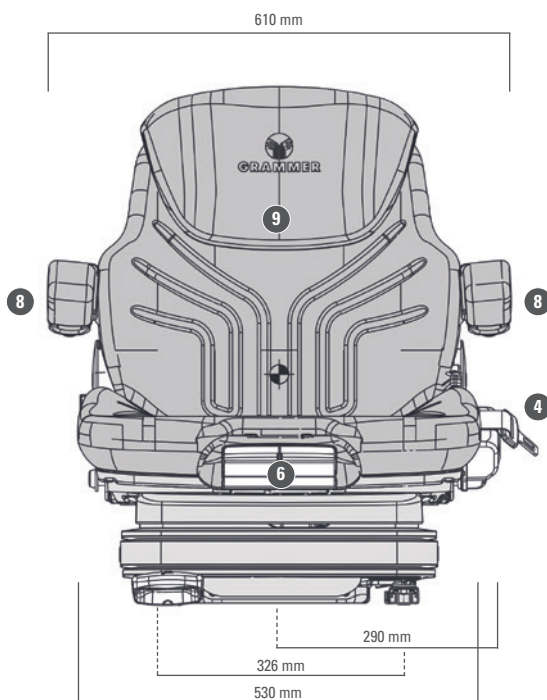

All dimensions in mm.  
Subject to technical changes.