



PRIMO[®] EVOLUTION

High-End Premium Seat
with Active Seat Climate Control



GRAMMER

TECHNICAL DATA

PRIMO® EVOLUTION

With its comprehensive range of features and innovative low-frequency suspension, this top-of-the-line product boasts the best sitting and suspension comfort in its class. Active seat climate control removes body moisture. The integrated seat heating ensures a comfortable temperature. In addition to a pneumatic lumbar support, the Primo Evolution also features active adjustment to the operator's weight: a major advantage when vehicles are used by multiple drivers. The seat automatically responds to even the slightest difference in weight to ensure that vibrations are optimally attenuated.



Pneumatic suspension



Low-Frequency Suspension



Pneumatic Lumbar Support



Electronic Weight Adjustment



Active Climate System

Features ● Standard ○ Optional

	PRIMO® EVOLUTION
Article no. fabric Compressor 12V	1292329
Shock absorber nonadjustable	●
Suspension	
Pneumatic suspension with compressor	●
Low-frequency suspension	●
Suspension stroke 110 mm	●
Weight adjustment 45 - 170 kg, electronic	●
① Climate system active	●
② Fore/aft adjustment 210 mm	●
③ Lumbar support pneumatic	●
④ Adjustable backrest angle	●

	PRIMO® EVOLUTION
⑤ Backrest extension	●
⑥ Restraint system	●
Seat cushion width	490 mm
⑦ Seat heating	●
⑧ Adjustable seat cushion depth and angle	●
Operator presence switch (OPS)	●
OPTIONAL FEATURES	
⑨ Document box	○
⑩ Armrests height-adjustable	○
Fore/aft isolator*	○

* Force/after isolator not for earth-moving machinery

Measurements (installation dimensions)

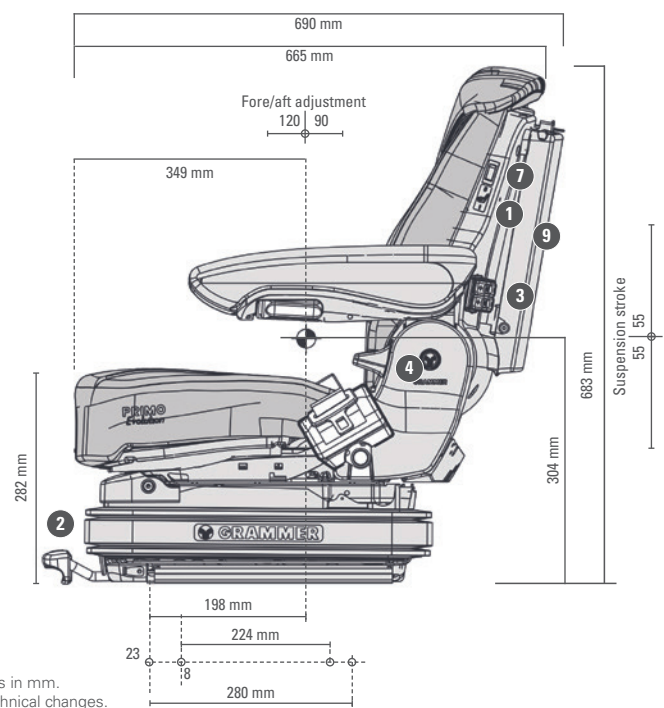
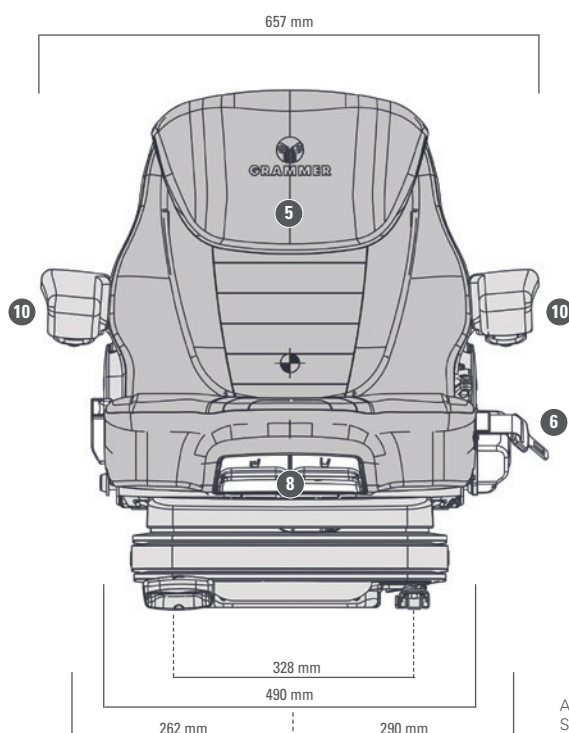

All dimensions in mm.
Subject to technical changes.